

Low-Voltage H-Bridge Motor Driver

Description

The FS4005D is a H-bridge driver that can drive one DC motor or other devices like solenoids. It provides an integrated motor driver for cameras, consumer products and other application with low-voltage or battery-powered motion control.

The FS4005D operates on a motor power supply voltage V_M from 0V to 10V and a device power supply voltage V_{CC} from 2.1V to 5.5V. It can deliver motor peak current up to 1.7A per channel.

The internal safety features include under-voltage lockout, over current protection and thermal shutdown.

Features

- Internal H-bridge Driver
- Separate Motor and Logic Supply
 - Motor V_M : 0V to 10V
 - Logic V_{CC} : 2.1V to 5.5V
- Low Sleep Current
 - I_{VMQ} : 1 μ A
 - I_{VCCQ} : 10nA
- Low MOSFET on-Resistance:
HS+ LS=280m Ω
- Thermal Shutdown
- Under-Voltage Lockout Protection
- Over Current Protection
- DFN2*2-8L Package
- ROHS Compliant and Halogen Free

Applications

- Robotics
- DSLR Lenses
- Cameras
- Battery Powered Toys
- Consumer Products

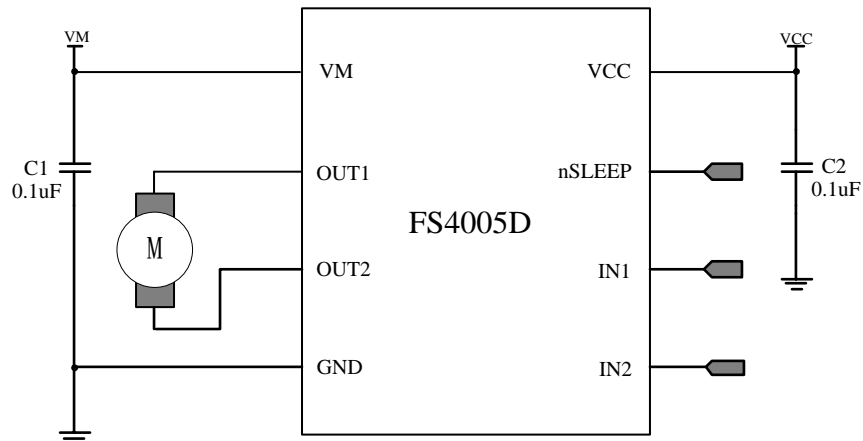
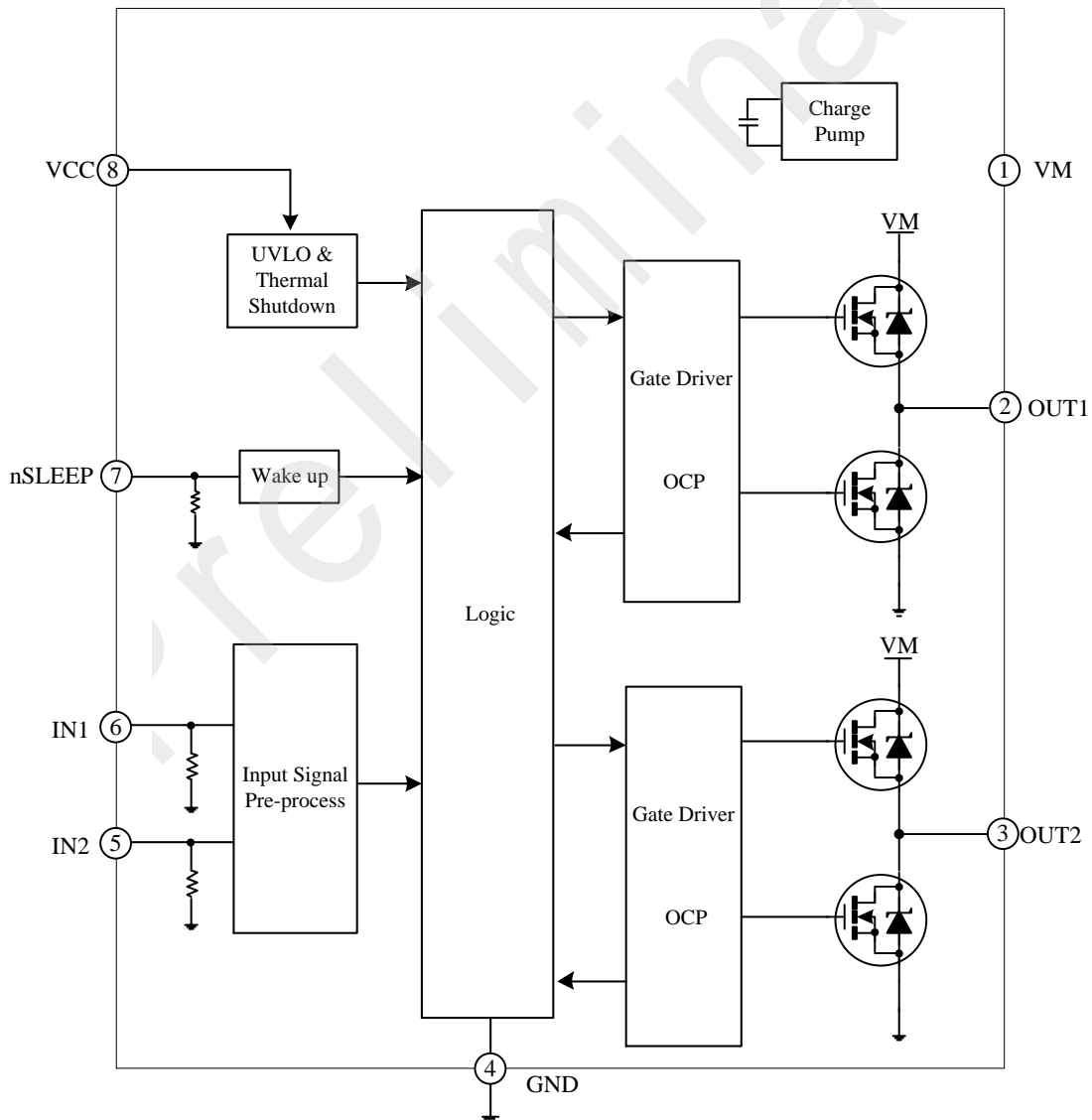
Typical Application Circuit

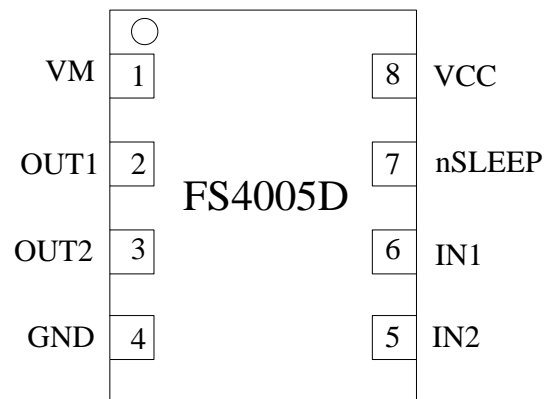
Functional Block Diagram

Pin Configuration

Pin Description

Pin	Name	Description
1	VM	Motor power supply
2	OUT1	Motor output 1
3	OUT2	Motor output 2
4	GND	Device ground
5	IN2	Input 2
6	IN1	Input 1
7	nSLEEP	Sleep mode input
8	VCC	Logic power supply

Absolute Maximum Ratings

Exceeding the Absolute Maximum ratings may damage to the device.

Symbol	Description	Min	Max	Unit
V _M	Motor power supply voltage	-0.3	11	V
V _{CC}	Logic power supply voltage	-0.3	6.5	V
V _{OUT1,2}	OUT _{1,2} voltage	-0.3	V _M +0.7	V
V _{LOGIC}	Logic input voltage	-0.3	6.5	V
T _J	Maximum operating junction temperature	---	150	°C
T _L	Lead temperature (soldering 30 seconds)	---	260	°C
T _S	Storage temperature range	-40	150	°C

Note1: In any case, power dissipation should not exceed P_D.

Note2: Voltages above the absolute maximum ratings may damage the chip.

Recommended Operating Conditions

The device is not guaranteed to operate beyond the Maximum Recommended Operating Conditions.

Symbol	Description	Min	Typ	Max	Units
V _M	Motor power supply voltage	0	---	10	V
V _{CC}	Logic power supply voltage	2.1	---	5.5	V
I _{OUT}	Motor peak current	---	---	1.7	A
f _{PWM}	Externally applied PWM frequency	0	---	250	kHz
V _{LOGIC}	Logic input voltage	0	---	5.5	V
T _A	Operating Junction temperature	-40	---	85	°C

Static Electrical Characteristics
 $V_M=5V, V_{CC}=3V, T_A=25^{\circ}C$, unless otherwise specified.

Symbol	Description	Min	Typ	Max	Units	Conditions
Power Supply						
V_M	VM operating voltage	0	---	10	V	
I_{VM}	VM quiescent current	---	0.3	0.5	mA	nSLEEP=1, $I_{OUT}=0$
I_{VMQ}	VM sleep current	---	---	1	μA	nSLEEP=0
V_{CC}	VCC operating voltage	2.1	---	5.5	V	
I_{VCC}	VCC quiescent current	---	1	1.5	mA	nSLEEP=1, $I_{OUT}=0$
I_{VCCQ}	VCC sleep current	---	---	10	nA	nSLEEP=0
Integrated MOSFETs						
V_F	Body diode forward voltage	---	0.9	1.4	V	$I_{OUT}=800mA$
$R_{DS(ON)}$	HS+LS FET output on resistance	---	280	---	$m\Omega$	$I_{OUT}=800mA$
Control Logic						
V_{ON}	UVLO rising edge threshold	---	1.9	2.2	V	
V_{HYS}	UVLO hysteresis	---	0.1	---	mV	
V_{IH}	Input logic high voltage	0.55* VCC	---	---	V	INx, nSLEEP
V_{IL}	Input logic high voltage	---	---	0.25* VCC	V	INx, nSLEEP
R_{PD}	Input pulldown resistance	---	140	---	$k\Omega$	INx
		---	100	---	$k\Omega$	nSLEEP
Motor Driver						
t_{ON}	Turn on propagation delay time	---	50	100	ns	
t_{OFF}	Turn off propagation delay time	---	50	100	ns	
t_R	Rise time	---	40	---	ns	100 Ω to GND
t_F	Fall time	---	20	---	ns	100 Ω to VM
t_{WAKE}	Sleep mode wakeup time	---	8	17	μs	
Protection Circuitry						
I_{OCP}	Over current protection trip level	1.8	---	---	A	
t_{DEG}	OCP deglitch time	---	2	---	μs	
t_{OCP}	Over current protection period	---	1.1	---	ms	
T_{TSD}	Thermal shutdown temperature	---	160	---	$^{\circ}C$	
T_{TSDH}	Thermal shutdown hysteresis	---	35	---	$^{\circ}C$	

Note: All voltages are specified with respect to the corresponding GND

Operation Description

The FS4005D is an integrated motor driver using for DC motor or other devices like solenoids. The device integrates NMOS H-bridge. It can be powered with a motor power supply voltage from 0V to 10V and a device power supply voltage VCC from 2.1V to 5.5V.

The motor output current can be controlled by an external pulse width modular.

The FS4005D provides a low-power sleep mode that enables the system to save power when not driving the motor. It also includes under-voltage lockout, temperature shutdown and over current protection.

External PWM Control

The motor current can be regulated by applying external PWM signals on the input pins. The IN1 and IN2 input pins control the state of the OUT1 and OUT2. Table 1 shows the logic.

Table 1 H-bridge logic

IN1	IN2	OUT1	OUT2
L	L	High impedance	High impedance
L	H	GND	VM
H	L	VM	GND
H	H	GND	GND

Sleep mode

Driving nSLEEP low will put the device into a low-power sleep state. In this state, the H-bridge is disabled, the charge pump is stopped, all internal logic is reset, and all internal clocks are stopped. When returning from sleep mode, a wakeup time is needed before the motor driver becomes fully operational.

Over current protection

A current monitor circuit on each MOSFET limits the current through the MOSFETs by limiting the gate drive. If the current limit persists for longer than the OCP deglitch time, all MOSFETs in the H-bridge will be disabled. The driver will be re-enabled after the OCP retry period. If the fault condition is still present, the cycle repeats.

Over current conditions are detected independently on both high-side and low-side devices, so a short to ground, supply or output short will all result in an over current shutdown.

Thermal shutdown

If the junction temperature exceeds the threshold voltage, all MOSFETs in the H-bridge will be shut down. Once the temperature has fallen to a safe level, operation will automatically resume.

Under-voltage lockout

If the voltage of VCC falls below the UVLO falling threshold voltage, the die shuts down. Operation will resume when the supply voltage rises above the UVLO rising threshold voltage.

The VM supply voltage does not have any undervoltage lockout, so as long as VCC rising threshold voltage, the internal device logic will remain active. This means that VM voltage may drop to 0V, however, the load may not be sufficiently driven at low VM voltage.

Preliminary

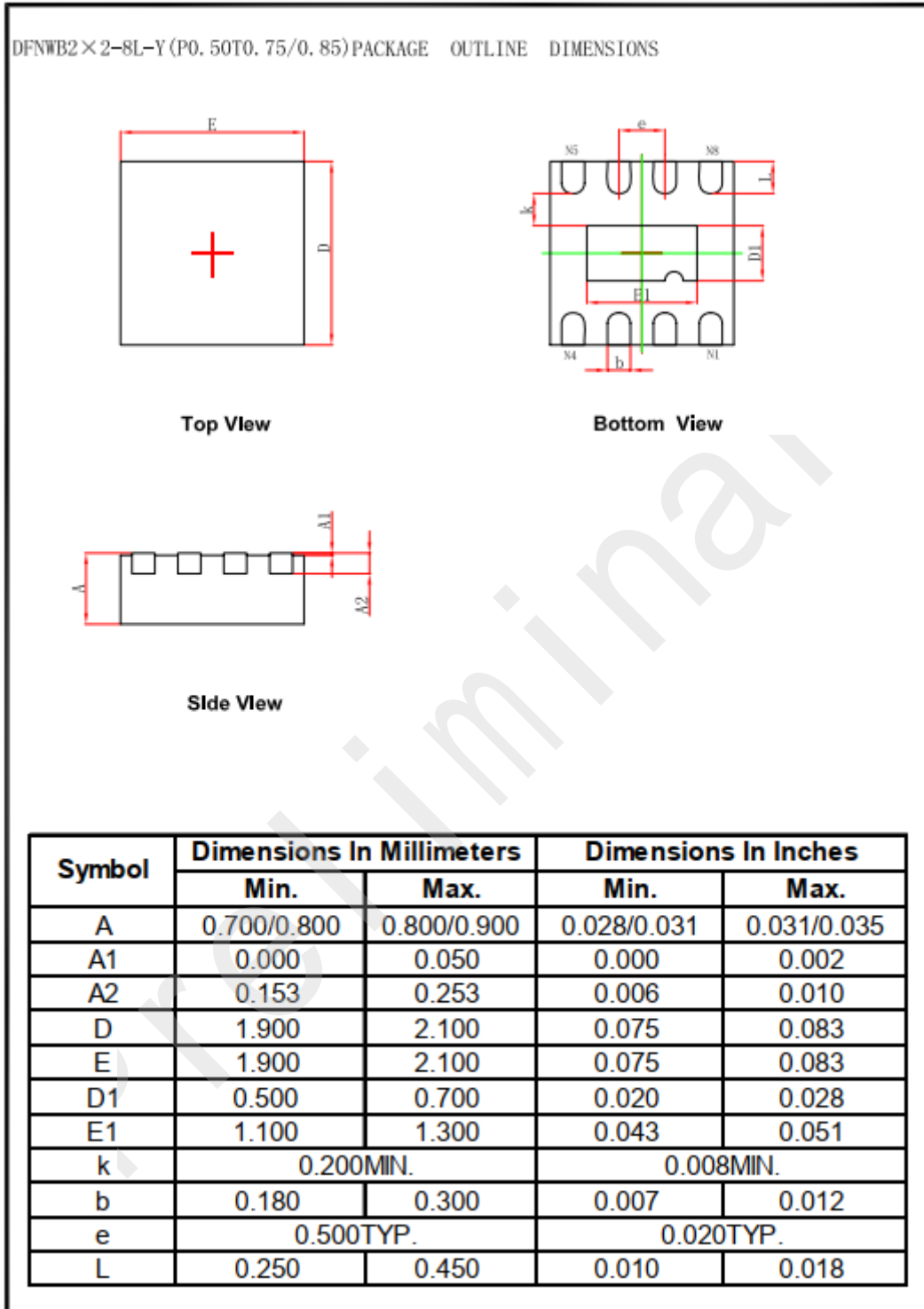
Package size (DFN8)

Part Number	Package Type	Marking ID	Package Method	Quantity
FS4005D	DFN2*2-8L	FS4005D	Tape&Reel	4000

Copyright Notice

Copyright by Fortior Technology (Shenzhen) Co., Ltd. All Rights Reserved.

Right to make changes —Fortior Technology (Shenzhen) Co., Ltd reserves the right to make changes in the products - including circuits, standard cells, and/or software - described or contained herein in order to improve design and/or performance. The information contained in this manual is provided for the general use by our customers. Our customers should be aware that the personal computer field is the subject of many patents. Our customers should ensure that they take appropriate action so that their use of our products does not infringe upon any patents. It is the policy of Fortior Technology (Shenzhen) Co., Ltd. to respect the valid patent rights of third parties and not to infringe upon or assist others to infringe upon such rights.

This manual is copyrighted by Fortior Technology (Shenzhen) Co., Ltd. You may not reproduce, transmit, transcribe, store in a retrieval system, or translate into any language, in any form or by any means, electronic, mechanical, magnetic, optical, chemical, manual, or otherwise, any part of this publication without the expressly written permission from Fortior Technology (Shenzhen) Co., Ltd.

Fortior Technology (Shenzhen) Co.,Ltd.

Room203, 2/F, Building No.11, Keji Central Road2,
Software Park, High-Tech Industrial Park, Shenzhen, P.R. China 518057
Tel: 0755-26867710
Fax: 0755-26867715
URL: <http://www.fortiortech.com>

Contained herein

Copyright by Fortior Technology (Shenzhen) Co., Ltd all rights reserved.