

FT1215Q

Three Phase Sinusoidal BLDC Motor Driver

Overview

The FT1215Q is a Three-Phase Sinusoidal BLDC Motor Driver. It comes with the advanced Hall sensor design and users can choose to use 1 Hall or 3 Halls according to the actual conditions. Due to its adaptive features and wide power-supply range capabilities, it is intended to cover a wide range of motor characteristics, while requiring little tuning from the user. Speed adjustment can be achieved through either direct-PWM or analog voltage control. Speed indicator is provided through a Frequency Generator output, generating digital pulse with its frequency proportional to the speed of the motor.

Protection functions of FT1215 are comprehensive including lock protection and automatic recovery, under voltage, thermal shutdown, current limit and over current protections. These prevent the control circuits and the motor from being damaged, particularly under stressed applications and demanding environments.

Features

- Selectable SVPWM (sine-wave) or BLDC (120°) drives
- 1 Hall or 3 Halls can be selected
- Hall sensor/ Hall IC input supported
- PWM speed input
- Analog speed input
- lead angle control
- Soft start
- FG (Frequency Generator) and RD (Rotation detection) output
- Current limit and internal over current protection
- Lock protection
- Built-in thermal shutdown protection (TSD)
- Built-in Under Voltage Lock Out (UVLO)
- Low Rds (1.0Ω)

Block Diagram

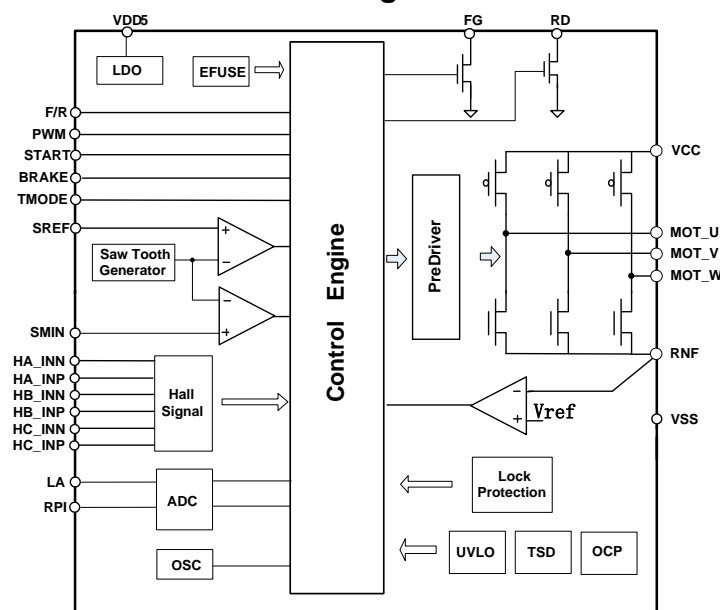

1. Pin Assignment

Package: QFN24 (4x4)

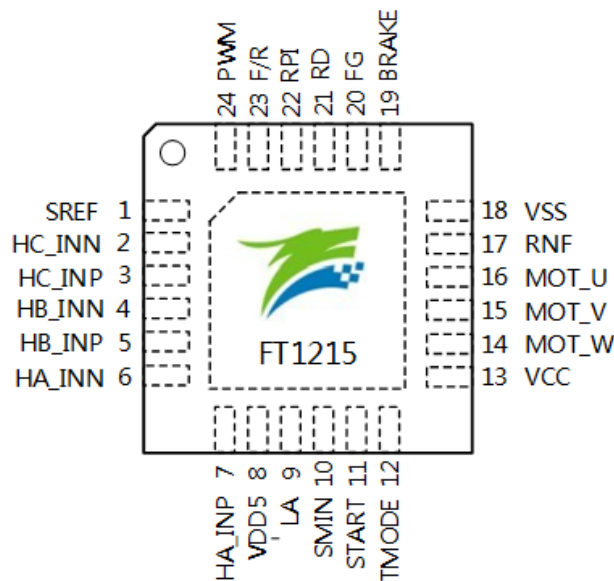

Table 1 Pin Configuration

PIN NO.	PIN Name	Type	Description
1	SREF	I	Analog input voltage for speed adjustment.
2	HC_INN	I	Hall C - Sensor Input. Phase-W magnetic field detection.
3	HC_INP	I	Hall C + Sensor Input. Phase-W magnetic field detection.
4	HB_INN	I	Hall B - Sensor Input. Phase-V magnetic field detection.
5	HB_INP	I	Hall B + Sensor Input. Phase-V magnetic field detection.
6	HA_INN	I	Hall A - Sensor Input. Phase-U magnetic field detection.
7	HA_INP	I	Hall A + Sensor Input. Phase-U magnetic field detection.
8	VDD5	O	Digital power output, LDO DC5V output for digital signal.
9	LA	I	Lead angle select analog input
10	SMIN	I	Minimum speed setting
11	START	I	Motor start input. High: Start; Low: Free. Internal pull-up
12	TMODE	I	Test signal input, connect to GND
13	VCC	P	Power supply
14	MOT_W	O	Motor output W
15	MOT_V	O	Motor output V
16	MOT_U	O	Motor output U
17	RNF	O	Output current detection pin
18	VSS	G	Signal and power ground.
19	BRAKE	I	Brake signal input, Low: Brake. Internal pull-up.
20	FG	O	Open drain. Frequency Generator, speed signal output.
21	RD	O	Open drain. Motor rotate detection output.
22	RPI	I	Soft-start PWM duty cycle setting.
23	F/R	I	Motor rotation direction input
24	PWM	I	PWM input for speed adjustment. Internal pull-up

2. Absolute Maximum Ratings (@Ta=25°C)

Table 2

Parameter	Symbol	Condition	Ratings	Unit
Power supply voltage	VCC max		30	V
Output current	I _{OUT} max	Peak (startup and lock rotor)	1.5	A
		Duty cycle = 100%, VCC=12V	800	mA
		Duty cycle = 100%, VCC=24V	700	mA
Logic input pin withstand voltage	V _{logic} max		5.5	V
RD/FG output pin withstand voltage	V _{FG} max		5.5	V
RD/FG output current	I _{FG} max		10	mA
Operating temperature	Topr		-40 ~ +85	°C
Storage temperature	Tstg		-65 ~ +150	°C

3. Recommended Operating Conditions

Table 3

Parameter	Symbol	Condition	Ratings	Unit
Power supply voltage	VCC		4.5~28	V

4. Electrical Characteristics

Table 4 (Unless otherwise specified, Ta = 25°C, VCC = 24 V)

Parameter	Symbol	Condition	Ratings			Unit
			Min.	Typ.	Max.	
Power supply current 1	I _{CC1}	Working current	-	15		mA
Power supply current 2	I _{CC2}	Standby current	-	1.5		mA
Output Block						
High-side switch ON resistance	R _{on} (H)	I _O = 0.5A	-	0.55	0.9	Ω
Low-side switch ON resistance	R _{on} (L)	I _O = 0.5A	-	0.45	0.7	Ω
5V Regulator Block						
Regulator voltage	V _{dd5}	I _o = 10 mA	4.75	5	5.25	V
Regulator output current	I _{v5out}	V _{reg5} =5V			10	mA
Analog I/O Section *Note1						
Analog Input range			0		5	V
Hall Input Pin *Note2						
Hall sensor input sensitivity	V _{HN}	Zero peak value (including offset and hysteresis)	-	10	20	mV
Digital I/O Section *Note3						
Digital high-level input voltage	V _{dinh}	-	2.3	-	5.3	V
Digital low-level input voltage	V _{dinl}	-	0	-	1.0	V
Digital I/O internal pull up resistor	R _{dio}	-	150k	200k	250k	ohm

Parameter	Symbol	Condition	Ratings			Unit
			Min.	Typ.	Max.	
Internal PWM Block						
Saw tooth Frequency	VPWM		22.5	25	27.5	KHz
VPWM High Level Voltage	VPWMH		3.56	3.75	3.94	V
VPWM Low Level Voltage	VPWML		0.71	0.75	0.79	V
FG/RD Output Pin						
FG/RD output pin low-level voltage	VFG	When I _o = 5 mA	-	0.1	0.2	V
Thermal Protection Circuit						
Thermal protection circuit operating temperature	TSD	Design target	-	165	-	°C
Temperature hysteresis width	ΔTSD	Design target	-	30	-	°C
Low-Voltage Detection						
Low voltage detection voltage	UVLO			3.3		V
ADC						
Input range	V _{in}		0	-	VDD5	V
Resolution	N			6		BIT

Notes:

*Note1: LA、SREF、SMIN、RPI

*Note2: HA_INN、HA_INP、HB_INN、HB_INP、HC_INN、HC_INP

*Note3: F/R、START、PWM、BRAKE

Functional Description and Notes

Please read the following notes before designing driver circuits with FT1215Q.

1. Motor Start.

A three phase sine drive PWM generator provides the controlling inputs to the power bridge based on rotor position derived from Hall element inputs. For 3 Hall mode, the duty cycle of PWM is determined by RPI. The duty cycle of PWM increases proportionally with the increasing RPI voltage, while the starting torque increases proportionally with the duty cycle of PWM.

For 1 Hall mode, the duty cycle of PWM and the frequency of commutation are determined by the RPI pin and the RSF pin separately. The duty cycle of PWM increases proportionally with the increasing RPI voltage, while the period of commutation increases proportionally with the RSF voltage. The RSF and RPI voltage settings may vary depending on the motor type and load, so that they should be experimentally adjusted carefully. Starting of motor may fail if unsuitable values of RSF and RPI are used. The voltage range of RPI and RSF is 0V to VDD5. When the motor rotates, generating stable and detectable Hall signal, sensorless start mode changes to Hall operation mode.

2. Hall Selection and Hall insensitive

User can choose 1 Hall or 3 Hall according to the actual conditions. HA must be used if 1 Hall mode is chosen.

The default setting is 3 Hall mode. 1 Hall can be set by programming efuse. When 1 Hall mode is chosen, HC_INP pin changes to RSF for the start of 1Hall.

Hall insensitive technique is adopted to eliminate product yield loss caused by hall misalignment in motor, as production, assembly, testing and transportation may all cause reposition of hall sensor.

3. Differential Hall Signal

HA_INN \ HA_INP \ HB_INN \ HB_INP \ HC_INN \ HC_INP are the differential Hall sensor inputs from the assembled motor and must be proportionately stepped down to less than VDD5 for IC protection. HA_INP \ HB_INP \ HC_INP are the Hall IC inputs from the assembled motor, if Hall ICs are used.

4. SVPWM Mode and BLDC Mode

FT1215Q can run in SVPWM mode for motor control. Under SVPWM mode, the phase currents are sinusoidal for acoustic noise reduction. The corresponding sequence diagram is shown in Figure 1 and Figure 2.

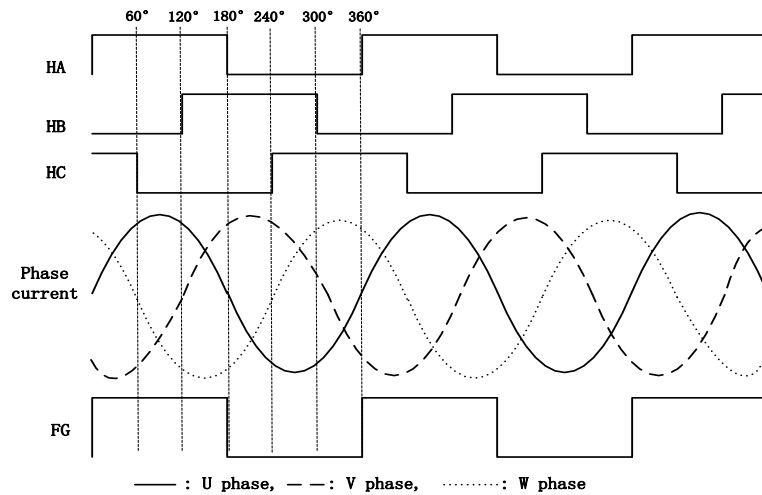

Figure 1 Sequence diagram for 3 Hall

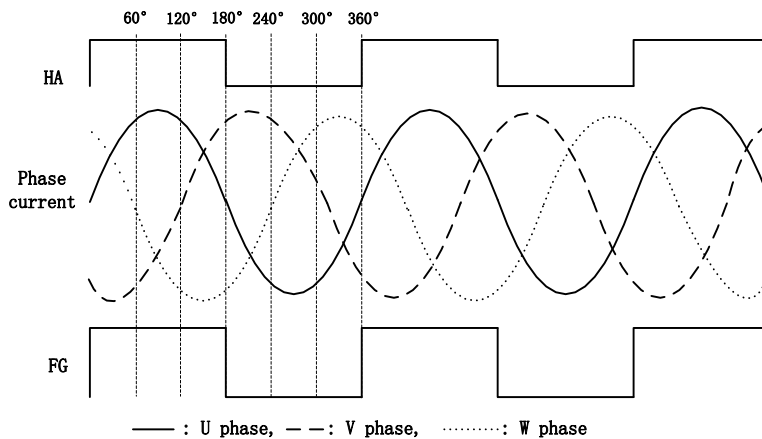

Figure 2 Sequence diagram for 1 Hall

FT1215Q can also be programmed to drive the motor with the traditional BLDC (120°) mode. The voltage and current sequence diagram is shown in Figure 3.

FT1215Q can select synchronous rectification in the BLDC mode by programming efuse, and is intended to reduce heat generation compared to diode regeneration.

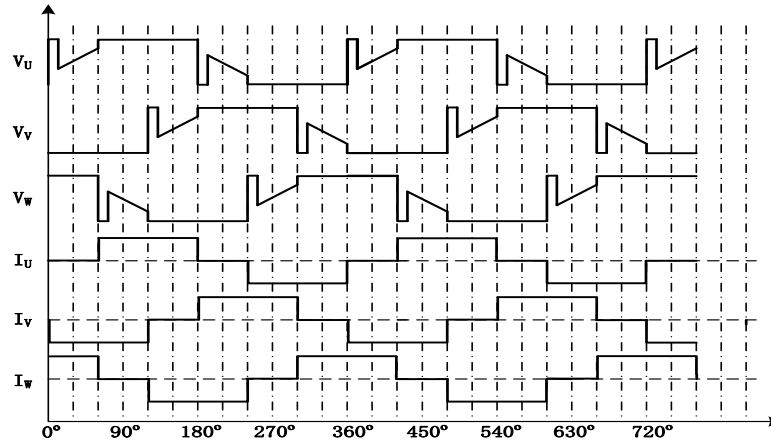

Figure 3 Voltage and Current of BLDC(120°)

5. Speed Control Methods

FT1215Q has two methods to adjust the motor speed, using PWM pin by adjusting its duty cycle or using SREF pin by adjusting the voltage level. Please note that during speed adjustment with PWM, SREF must be disabled and pulled high. Conversely during speed adjustment with SREF, PWM must be disabled and pulled high. When adjusting speed with PWM, the speed is varied by performing switching in accordance with the duty cycle that is provided to the PWM pin. When adjusting speed with SREF, speed is adjusted by an internally generated PWM with the duty cycle determined by the equation:

$$Duty_cycle = \frac{V_{SREF} - 0.75}{3}$$

When the SREF pin is connected to VDD5 and the motor speed will rise to full speed. When SREF pin is lower than 0.75V during operation, the motor will slow down and stop.

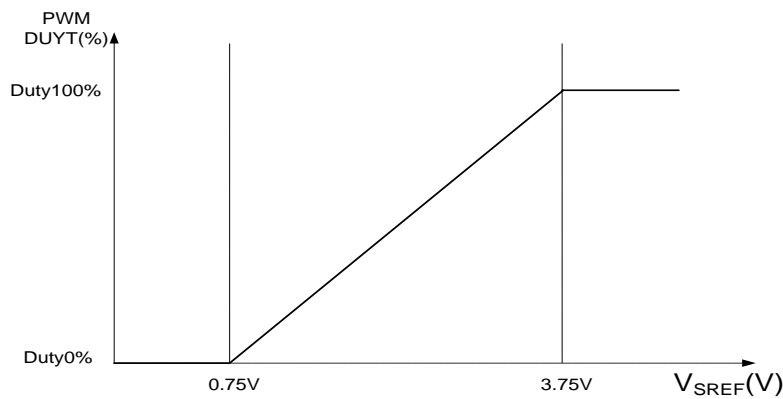

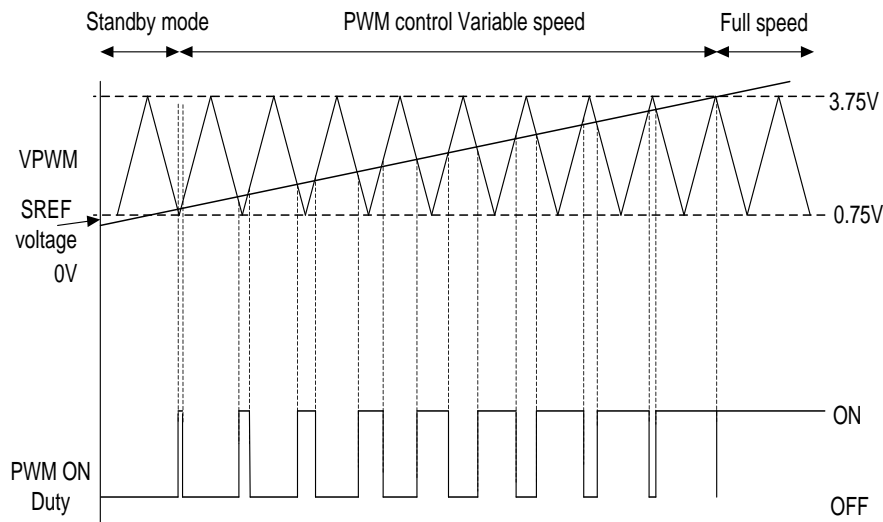

Figure 4 Rotation Speed Control Chart

When the rotate speed is very low, the motor possible appear discontinuous state of rotation. Minimum speed setting is controlled by SMIN pin to prevent this condition. When the voltage of SREF pin is less than the voltage of SMIN pin, PWM is immediately turned off. SMIN pin can be pulled low or set by programming efuse if minimum speed limit is not needed.

6. Frequency Generator Function

The Frequency Generator output generates a rotation pulse to give information about the speed of motor. The default setting is 1 pulse per electrical degree. The FG pin is an open drain output, connecting to a logical voltage level through an external pull-up resistor. This pin can be left open if unused.

7. Setting of Function

Many functions can be set by programming efuse within the chip. These functions include: selection of SVPWM (sine-wave) or BLDC (120°) modulation mode, selection of Synchronous rectification (Synchronous rectification and normal mode), etc.

8. Brake Function

FT1215Q comes with brake function. Braking comes intelligently for protective purpose. When BRAKE pin is set to low, if the motor is rotating above the brake threshold speed, output MOSFETs are turned off to brake the motor. However, if the motor is rotating below the brake threshold speed, and the lower legs of the output MOSFETs are turned on to brake the motor. The reason for this distinction is to protect the MOSFETs from excessive braking currents due to large back-EMF. User can set the safe back-EMF for short braking by setting brake threshold speed using the internal efuse.

9. Lead Angle Correction

The lead angle of generated motor driving signals relative to the Hall signals can be shifted by an angle between 0 and 63 degrees. The lead angle control can be achieved by directly applying a voltage to the LA pin.

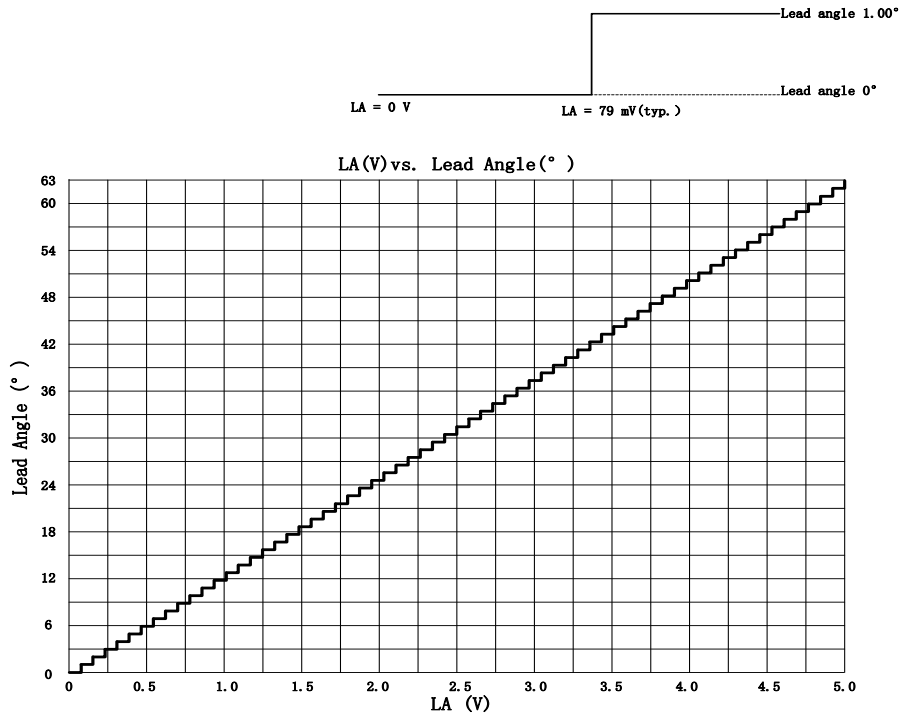

Figure 5 LA Vs Lead Angle

<Typical Characteristics of the LA versus Lead Angle>

Step	LA (V)	Lead angle(°)	Step	LA(V)	Lead angle(°)	Step	LA (V)	Lead angle(°)
0	0.00	0.00	22	1.75	22.00	44	3.49	44.00
1	0.08	1.00	23	1.83	23.00	45	3.57	45.00
2	0.16	2.00	24	1.90	24.00	46	3.65	46.00
3	0.24	3.00	25	1.98	25.00	47	3.73	47.00
4	0.32	4.00	26	2.06	26.00	48	3.81	48.00
5	0.40	5.00	27	2.14	27.00	49	3.89	49.00
6	0.48	6.00	28	2.22	28.00	50	3.98	50.00
7	0.56	7.00	29	2.30	29.00	51	4.05	51.00
8	0.63	8.00	30	2.38	30.00	52	4.13	52.00
9	0.71	9.00	31	2.46	31.00	53	4.21	53.00
10	0.79	10.00	32	2.54	32.00	54	4.29	54.00
11	0.87	11.00	33	2.62	33.00	55	4.37	55.00
12	0.95	12.00	34	2.70	34.00	56	4.44	56.00
13	1.03	13.00	35	2.78	35.00	57	4.52	57.00
14	1.11	14.00	36	2.86	36.00	58	4.60	58.00
15	1.19	15.00	37	2.94	37.00	59	4.68	59.00
16	1.27	16.00	38	3.02	38.00	60	4.76	60.00
17	1.35	17.00	39	3.10	39.00	61	4.84	61.00
18	1.43	18.00	40	3.17	40.00	62	4.92	62.00
19	1.51	19.00	41	3.25	41.00	63	5.00	63.00
20	1.59	20.00	42	3.33	42.00			

21	1.67	21.00	43	3.41	43.00			
----	------	-------	----	------	-------	--	--	--

10. Forward and Reverse

FT1215Q has an FR pin to set the motor for a forward spin or reverse spin. The spin direction of the motor can be changed when during normal operation or can be set before power up. During normal operation, when FR status is changed, the motor break first and after a waiting time (FR_DELAY), the motor is reverse. FR_DELAY is configurable with internal efuse and can be modified by user.

11. Lockup Protection and Automatic Restart

If motor rotation is abnormal, the internal detection circuit starts self-locking detection for a given time (Trun). If the motor keeps stalling under the Trun, the lock-up protection circuit disable the driver (by setting its outputs to high-impedance) in order to prevent the motor coil from burnout and the RD pin goes logic high. After a “waiting time (Twait)”, the lock-up protection is released and normal operation resumes. Similarly if rotation is abnormal for another time period, Trun, lock-up protection is triggered. Trun timing is configurable with internal efuse and can be modified by user. Twait timing is configurable with RSD pin. If automatic restart is not needed, it can be canceled with internal effuse and the motor remains stop after the first Trun.

The RD pin is an open drain output. During the lock-up protection condition, RD output will keep high until the lock-up protection is dismissed and restart completed. This pin can be left open if unused.

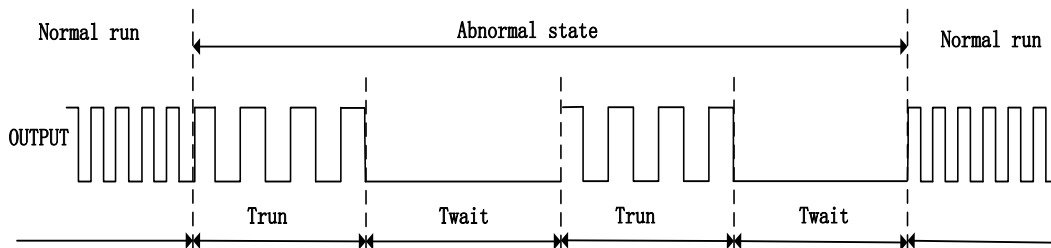

Figure6 Lock-up Protection and Automatic Restart

12. Current Protection

There are three methods of current protection: overload current protection, cycle by cycle current protection and build-in over current protection. The overload current protection and cycle by cycle current protection of the motor can be selected by setting internal efuse.

The current limit circuit limits the output current peak value to a level determined by the equation:

$$I = V_{RNF} / R_{RNF}$$

V_{RNF} is configurable with internal efuse and it has four level can be set by users. R_{RNF} is current detection resistor. For the overload current protection mode, the current limit circuit detects the voltage at the RNF input is higher than V_{RNF} and then reduces the duty cycle of PWM.

For the cycle by cycle current protection mode, when the voltage at the RNF input is higher than V_{RNF} , the current limit protection is generated and the output PWM is turned off and evaluated every PWM cycle.

For over current detection, if current is higher than 1.5A, the over current protection is triggered, PWM is immediately turned off. After a “waiting time” (Twait), the over current protection is released and FT1215Q restarts its operation with the startup sequence. If automatic restart is not needed, it can be canceled with internal efuse and the motor remains stop after the over current protection is triggered.

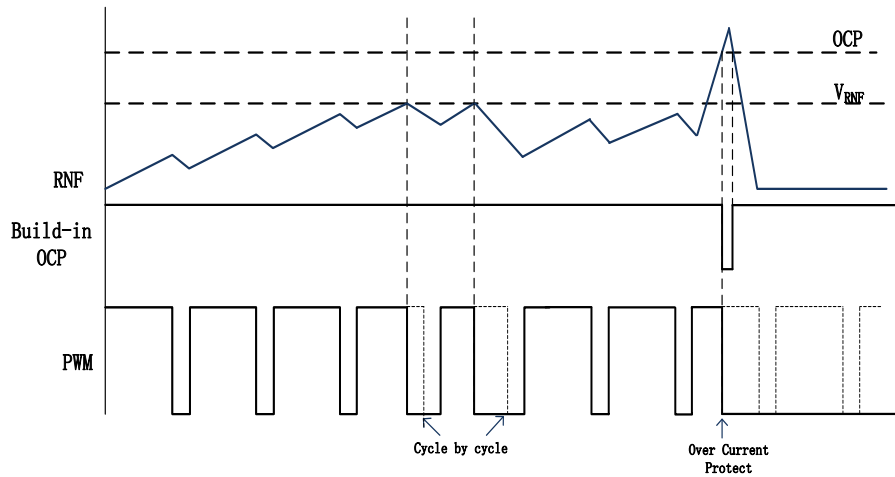

Figure7 Cycle by cycle current protection mode

13. UVLO.

FT1215Q has a built-in UVLO function block. The device will be locked out when VCC reaches 3.3 V and woke up at 3.3 V.

14. Thermal Protection.

FT1215Q has a built in thermal shunt down function, which will shut down the device when the junction temperature is over 165°C and will resume operating when the junction temperature drops back to 135°C.

5. Application Circuit Example

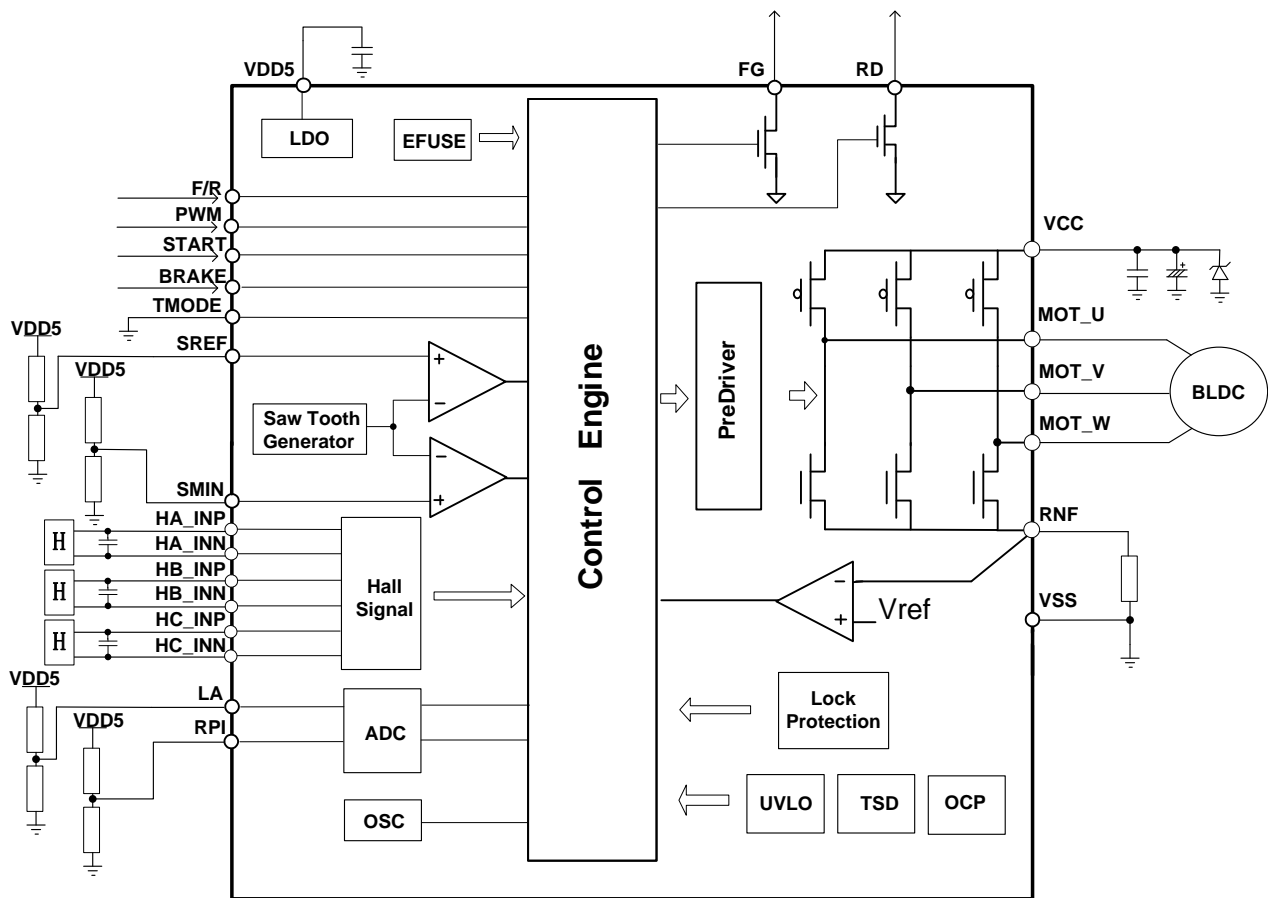

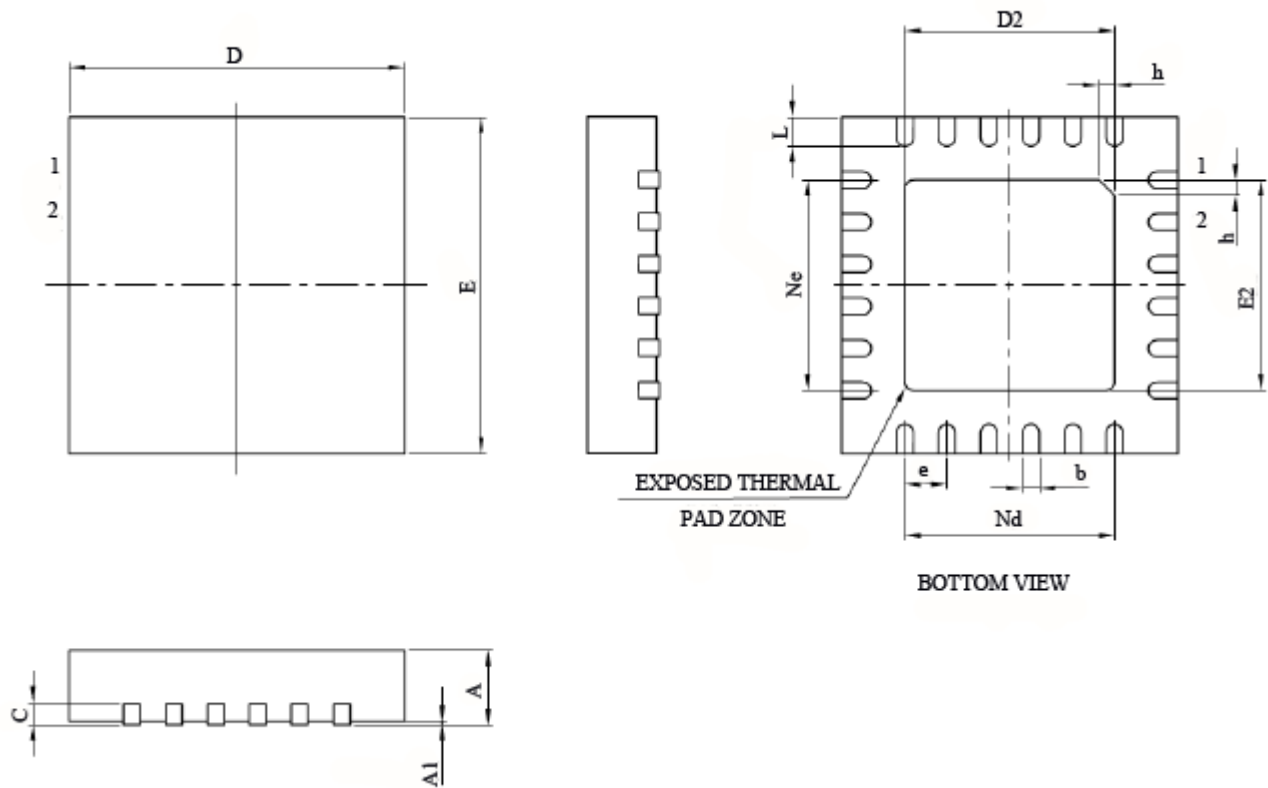
6. Package Information
Package: QFN24 (4x4)

SYMBOL	MILLIMETER		
	MIN	NOM	MAX
A	0.70	0.75	0.80
A1	—	0.02	0.05
b	0.18	0.25	0.30
c	0.18	0.20	0.25
D	3.90	4.00	4.10
D2	2.40	2.50	2.60
e	0.50BSC		
Ne	2.50BSC		
Nd	2.50BSC		
E	3.90	4.00	4.10
E2	2.40	2.50	2.60
L	0.35	0.40	0.45
h	0.30	0.35	0.40

Copyright Notice

Copyright by Fortior Technology (Shenzhen) Co., Ltd. All Rights Reserved.

Right to make changes —Fortior Technology (Shenzhen) Co., Ltd reserves the right to make changes in the products - including circuits, standard cells, and/or software - described or contained herein in order to improve design and/or performance. The information contained in this manual is provided for the general use by our customers. Our customers should be aware that the personal computer field is the subject of many patents. Our customers should ensure that they take appropriate action so that their use of our products does not infringe upon any patents. It is the policy of Fortior Technology (Shenzhen) Co., Ltd. to respect the valid patent rights of third parties and not to infringe upon or assist others to infringe upon such rights.

This manual is copyrighted by Fortior Technology (Shenzhen) Co., Ltd. You may not reproduce, transmit, transcribe, store in a retrieval system, or translate into any language, in any form or by any means, electronic, mechanical, magnetic, optical, chemical, manual, or otherwise, any part of this publication without the expressly written permission from Fortior Technology (Shenzhen) Co., Ltd.

Fortior Technology (Shenzhen) Co.,Ltd.

Room203, 2/F, Building No.11, Keji Central Road2,
Software Park, High-Tech Industrial Park, Shenzhen, P.R. China 518057
Tel: 0755-26867710
Fax: 0755-26867715
URL: <http://www.fortiortech.com>

Contained herein

Copyright by Fortior Technology (Shenzhen) Co.,Ltd all rights reserved.